

Freight Transport Information manual



Contents

Thank you for choosing Stena Line as your carrier	4	5. Arrival at the terminal	22
2. Suitability of equipment for shipment	5	5.1 High visibility clothing	22
2.2 Semi-trailers with reduced rear clearance	5	5.2 ISPS regulations and ID requirements	22
2.3 Trestle points	6	5.3 Speed limits	22
2.4 General securing requirements at sea	7	5.4 Cut-off times for shipment	22
2.5 Securing points on a semi-trailer	8	5.5 Use of mobile phones	22
3. Securing of loads on semi-trailers	9	5.6 Weight	22
3.1 General guidelines regarding securing loads for shipment	9	5.7 Paperwork	22
Vehicles carrying bricks	9	5.8 Driving around the Terminal and on board	22
Vehicles carrying wire-reinforcing mesh	9	5.9 Parking in the terminal	22
Vehicles carrying RSJ's or steel beams on a posted semi-trailer	9	5.10 Drugs and Alcohol	23
Vehicles carrying board products/pallets	10	5.11 Abusive behaviour	23
Curtain sided semi-trailers/tautliners	10	6. Check in	24
Vehicles carrying crushed Vehicles	10	6.1 Booking reference numbers	24
High centre of gravity semi-trailers	11	6.2 Storage	24
Vehicles carrying waste materials	12	6.3 Load description	24
Tanker semi-trailers	12	6.4 Hazardous goods paperwork and DGN's	24
Vehicles carrying animal skins	12	6.5 Hazardous labelling	24
Vehicles carrying cable reels	12	6.6 Refrigerated Loads	24
Vehicles carrying mixed loads	12	6.7 Overfilling of fuel tanks	24
Vehicles carrying coiled rod and bar	13	7. Security	25
Vehicles carrying wheeled and light tracked vehicles	14	7.1 Freight screening	25
Vehicles carrying engineering plant	14	8. Delivery of units to the terminal for shipment	26
Vehicles carrying agricultural type tractors	15	8.1 Drivers responsibilities	26
Vehicles carrying palletised loads	16	8.2 Driver accompanied vehicles	26
Insecure loads/partial loads	17	8.3 Collection from the terminal	27
Vehicles carrying banked or stacked semi-trailers	18	9. Shipment of specialised goods	28
Vehicles carrying concrete	19	9.1 Hazardous goods	28
Trailer Strength	20	Additional note regarding the shipment of hay/straw	29
4. Bookings	21	9.1 Animals	29
4.1 Information required	21	9.2 Horses	29
4.3 Abnormal loads (over-width, bulging etc.)	21	9.3 Refrigerated cargo (reefers)	29
4.4 Confirmation	21	9.4 Scrap metal	29
4.6 Cancellations	21	10. Damages	30
		11. Insurance	30
		Contact	31



Thank you for choosing Stena Line as your carrier

The purpose of this 'Information Manual' is to assist in understanding our requirements and procedures in order that we may transport your goods in a safe and efficient manner.

The responsibility for ensuring freight being presented for transport on our vessels, in terms of safety and security of the load, lies with the shipper. There are a number of statutory and local legal requirements in this respect and they must be adhered to.

Dimensions of trailers allowed on roads in respect of height, width and length vary from country to country and it is the shippers' responsibility to ensure that all freight presented is compliant. We fully accept that all pieces of equipment are not the same and that some may need special attention during loading and / or discharging.

Reference to 'CST' throughout this document refers to the Stena Line Freight Customer Services Team.

If there are any points that you are unsure of in this document then please contact your Stena Line Freight Sales representative.

All shipments are subject to Stena Line's 'Terms and Conditions of Carriage of Goods by Sea' Stena Line will not accept liability for damage to equipment, or cargo, which the owner has left on the terminal for more than 24 hours after arrival. The Masters of our vessels, by law, have the overriding authority to refuse any cargo presented for shipment if he/she considers that the cargo, for whatever reason to be unsafe.

2. Suitability of equipment for shipment

2.1 Dimensions

When you contact our CST you will be asked to provide information relating to the route, date and time of the sea passage required. You must also advise if there are any particular requirements regarding excessive length, width, weight and height.

Please refer to our route specific website for further detail:

www.stenalinefreight.com/routes

2.2 Semi-trailers with reduced rear clearance

Semi-trailers with tail lifts or reduced rear end clearance are at a greater risk of grounding during the loading/discharge process. Examples are shown below in figures 1, 2, 3 & 4.



Fig no. 1
Low tail bar extension



Fig no. 2
Spare wheel carrier lower than tail bar



Fig no. 3
Low tail bar on semi-trailer suitable for Fork Lift 'Piggy Back'



Fig no. 4
Low tail bar rear view

2.3 Trestle points

There are normally load-bearing areas underneath semi-trailers suitable for placing specially designed support frames (trestles) and are used during ferry crossings to assist in the necessary proper securing for the sea passage when no cab unit is attached. Load bearing areas are constructed of steel plate secured to the under frame of the trailer to the rear of the fifth wheel connection point, as per fig no. 7. Trestles are normally placed underneath the semi-trailer whilst it is still attached to the shunter/tug master.

The position of the load bearing area must allow enough room, forward of the landing legs, to place a trestle in position and have the rear wheels of the shunter underneath at the same time. It is a legal requirement to place trestles under all semi-trailers being shipped on our vessels in order that we comply with the statutory approved cargo securing requirements on our vessels.

It is not possible to ship semi-trailers that have no trestle point using landing legs only unless the terminal can provide a 'LOT' trestle, this is due to the motion of our ferries that may be experienced on passage due to adverse weather conditions. Please contact CST for further information if required. Normal dimensions of trestles are as shown in figure no. 6.

Figures no. 8 & 9 are examples of semi-trailers with no suitable load bearing area – these are not suitable for shipment as an unaccompanied semi-trailer.

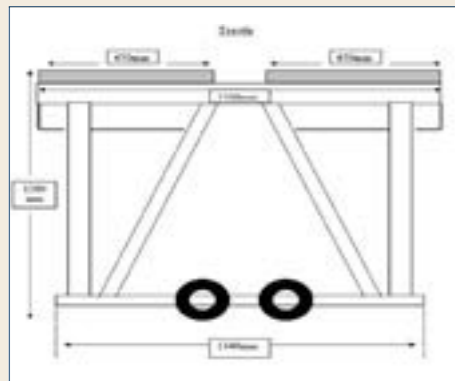

Fig no. 6 Normal dimensions of trestles



Fig no. 7 Load bearing area suitable for placement of a trestle along the marked arrows.



Fig no. 8



Fig no. 9



Fig no. 10 An example of a trestle in place correctly supporting a semi-trailer



Fig no. 11 Example of a suitable trestle points on a tank unit.

2.4 General securing requirements at sea

The International Maritime Organisation (IMO) is the global body that regulates the requirements for safe carriage of Freight vehicles aboard our Ferries at sea and we must abide by their recommendations as follows:

The following IMO recommendations securing/lashing points on road vehicles and securing the content should be followed:

- ➔ Securing points on road vehicles should be designed for securing the road vehicles to the ship and should have an aperture capable of accepting only one lashing. The securing point and aperture should be permitted varying directions of the lashing to the ship's deck. (if more than one aperture is provided at a securing point, each aperture should have the strength for the securing point in the table below);
- ➔ The same number of not less than two or not more than six securing points should be provided on each side of the road vehicle in accordance with the provisions of the table below;
- ➔ The minimum number and minimum strength of securing points should be in accordance with the following table. There are subject to the notes a), b) and c) below

Gross vehicle mass (GVM) (tonnes)	Minimum number of securing points on each side of the road vehicle	Minimum strength without permanent deformation of each securing point as lifted (kN)
3.5 ton < GVM < 20 ton	2	
20 ton < GVM < 30 ton	3	GVM x 10 X 1.2 N*
30 ton < GVM < 40 ton	4	

* Where N is the total number of securing points on each side of the road vehicle.



For road trains, the table applies to each component, i.e. to the motor vehicle and each semi-trailer, respectively.

Semi-trailer towing vehicles are excluded from the table on page 8. They should be provided with two securing points at the front of the vehicle, the strength of which should be sufficient to prevent lateral movement of the front of the vehicle. A towing coupling at the front may replace the two securing points.

If the towing coupling is used for securing vehicles other than semi-trailer towing vehicles, this should not replace or be substituted for the above-mentioned minimum number and strength of securing points on each side of the vehicle.

Semi-trailers by the nature of their design should not be supported on their landing legs during sea transport unless the landing legs are specially designed for that purpose and so marked. An uncoupled semi-trailer should be supported by a trestle or similar device placed in the immediate area of the drawplate so that the connection of the fifth-wheel to the kingpin is not restricted. A clearly visible mark on the outer sidewall of the semi-trailer, or on some other clearly visible place, shall indicate the location of the trestle. The trestle should be located, if possible, within the range of the horizontal plane of the gooseneck contour as shown in figure 1. If the semi-trailer has more than one fifth wheel coupling pin, the trestle location should be measured from the rearmost fifth wheel coupling pin position.

Vehicles/semi-trailers designed to transport loads likely to have an adverse effect on their stability such as hanging meat or liquids, must have a means of neutralising the suspension system in order to avoid a build up of turn over forces otherwise they will not be shipped.

2. 5 Securing points on a semi-trailer

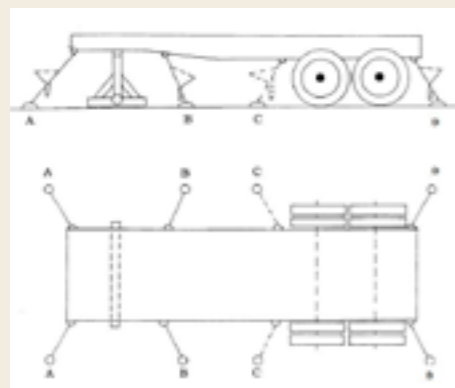

Fig no. 12 Required securing points on a semi-trailer



Fig no. 13 & 14 Clearly marked and well-located securing/lashing points

3. Securing of loads on semi-trailers

The load must be secure enough for shipment by sea where forces exerted on semitrailers can be well in excess of those on the road. If the load is deemed to be insecure it will be refused shipment until satisfactory securing has taken place which must be fitted by yourselves or an appointed agent.

3.1 General guidelines regarding securing loads for shipment

The following guidelines are given as a MINIMUM requirement, they do not cover all types of load but emphasise that all cargo to be shipped at sea must be secure. If advice is required please contact our [Customer Service Team](#).

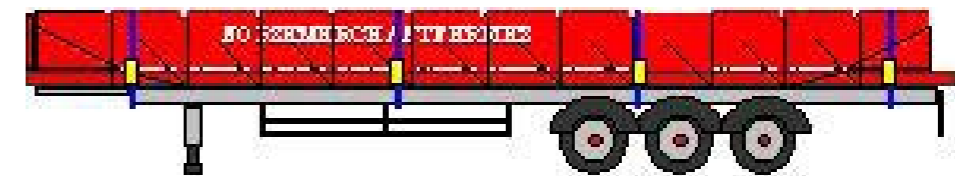

Vehicles carrying bricks

To be sheeted in all cases, rope to be used on each hook securing point.

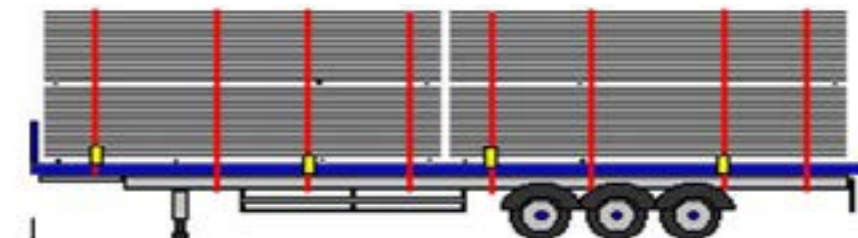

Vehicles carrying wire-reinforcing mesh

Each stack must be secured by at least 4 (webbing) straps to be tensioned on alternate sides of the stacked product with corner protection. The ratchets must be checked for tension and retightened, if required when depositing the semi-trailer at the port of departure.

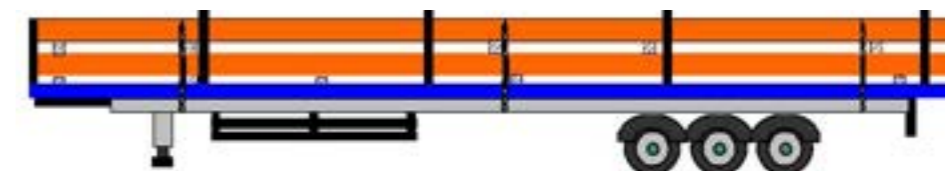

Vehicles carrying RSJ's or steel beams on a posted semi-trailer

At least 3 chains evenly spaced, with suitable timber skids placed on and between the lengths of the steel beams with the beams tight up to the headboard. The height of the steel beams must not exceed the height of the headboard.



Curtain sided semi-trailers/tautliners

All loads carried within a curtain-sided/tautliner semi-trailer should be secured as though they were being shipped on an open flatbed semi-trailer. Unless they are purposely designed for a specific load, the curtains/tarps must not be considered as part of any load restraint system. Bulging loads that extend outside the normal width of the semi-trailer will be refused shipment.

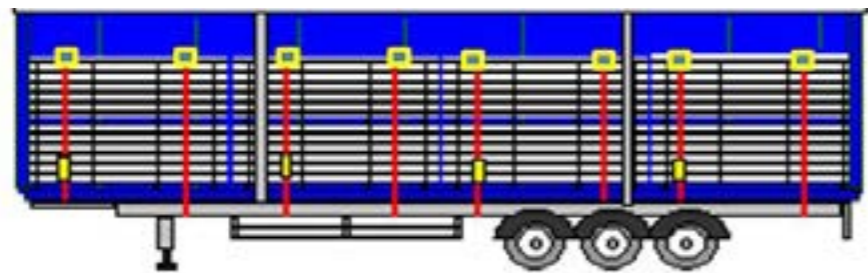

Vehicles carrying board products/pallets

At least 8 securing arrangements to be used on the total load, 2 per stack and to be tensioned on alternate sides of the stacked product.

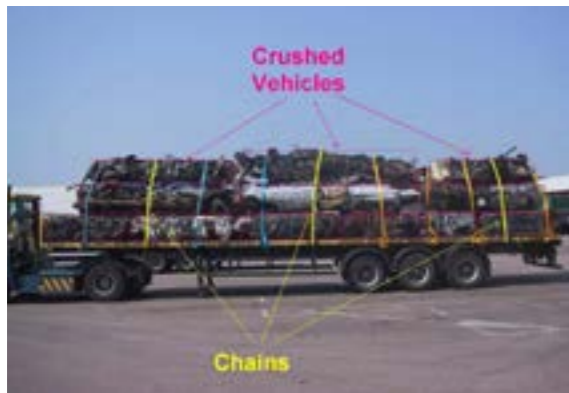

Vehicles carrying crushed Vehicles

All loads must be secured with sufficiently tensioned chains which ensure no parts of the load can fall off. Any leakage of oil or other fluid from the load will prevent shipment.

High centre of gravity semi-trailers

Double stacking semi-trailers and semi-trailers carrying hanging meat as shown in figures no. 20 & 21 can have a high centre of gravity which can make the load less stable and result in overturning if not packed correctly.



Care must be taken to ensure that the weight is carefully distributed to avoid overturning.

All meat must be hung from the hanging hooks in the semi-trailer. Meat must not be hung from ropes within the semi-trailer as this causes the load to be unstable in motion as shown in figure no. 22.

Fig no. 21



Fig no. 22



Vehicles carrying waste materials

If any of the load imposes over the rim of the semi-trailer it must be securely sheeted to ensure no parts of the load can fall off. Tippers carrying loads such as scrap engines or any part of the load that may leak oils must have a secure rubber seal around the rear door to prevent leakage of any kind. Tippers that are carrying waste loads (e.g. filter cake/sludge cake). Tippers carrying these loads must be fully sheeted and have a secure rubber seal around the rear door to prevent leakage.

Tanker semi-trailers

Drivers must ensure that all tank openings are firmly secured, including openings on top of the tank. Tanks may be manoeuvred up steep ramps on our vessels to be put into final stow positions

Vehicles carrying animal skins

Animal skins will only be accepted for shipment when contained within fully sealed units. If there is any leakage the units will be refused shipment.

Vehicles carrying cable reels

All cable reels shall be chocked to prevent longitudinal movement and shall be further secured with the use of heavy duty straps or chains, sufficient in strength to avoid movement whilst being transported on board.

Vehicles carrying mixed loads

When a load is composed of different items each part of the load must be secured in a manner suitable to a load of its type. This applies mainly to cross lashings. The longitudinal lashings must be adequate for the total weight of the load, and separators must be used so that no part of the load can move forward or rearward independently.

The following procedures should be followed when applicable.

- Where mixed loads involve heavy solid articles and light crushable boxes the heavier articles should provide the base and rear part ('A' in figure 16) and the light portion be loaded on top and to the front ('B' in figure 16)
- When loading different sizes of container small items should be central, with the larger items forming the outer walls of the load (see figure 17). Avoid as far as possible obstructions or projections beyond the vehicle sides
- Keep irregular shaped items for the upper part of the load where it is not possible to place them centrally within the load
- Special precautions may have to be taken when dangerous substances are included in a load. These include segregation of substances which may interact together, protection from rain and careful handling and stowage to reduce the risk of damage to vulnerable containers. The packages should be loaded in such a manner as to enable the labels to be easily read. (See Section 9)

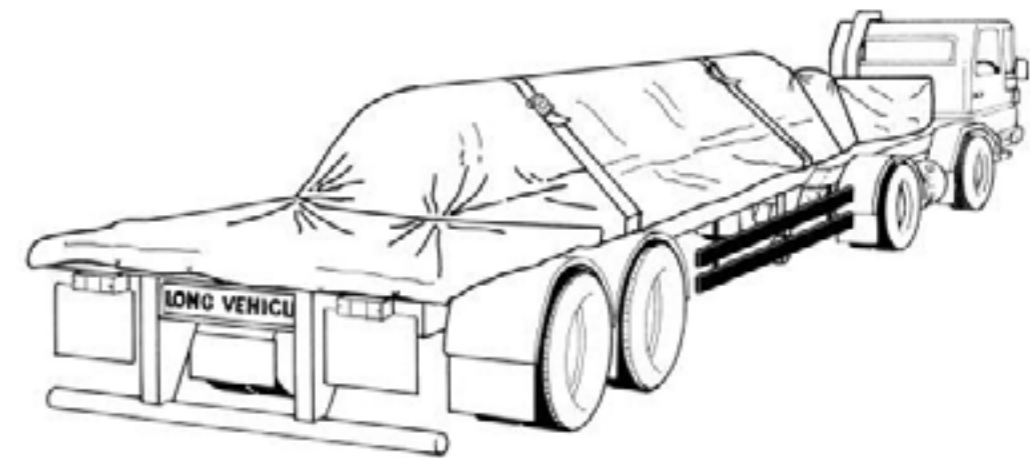
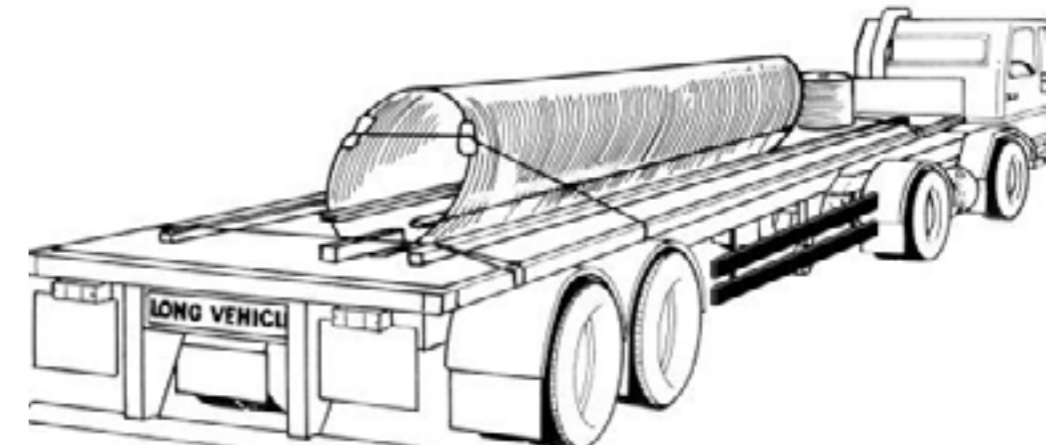

Vehicles carrying coiled rod and bar

These products should be carried bore horizontal in a single layer loaded either transversely or longitudinally. It is recommended that these loads are carried on a vehicle fitted with special loading frames or cradles designed to contain the coils. If this is not possible, then all the restraint will have to be provided by securing devices, preferably chains or webbing fitted with tensioning devices.

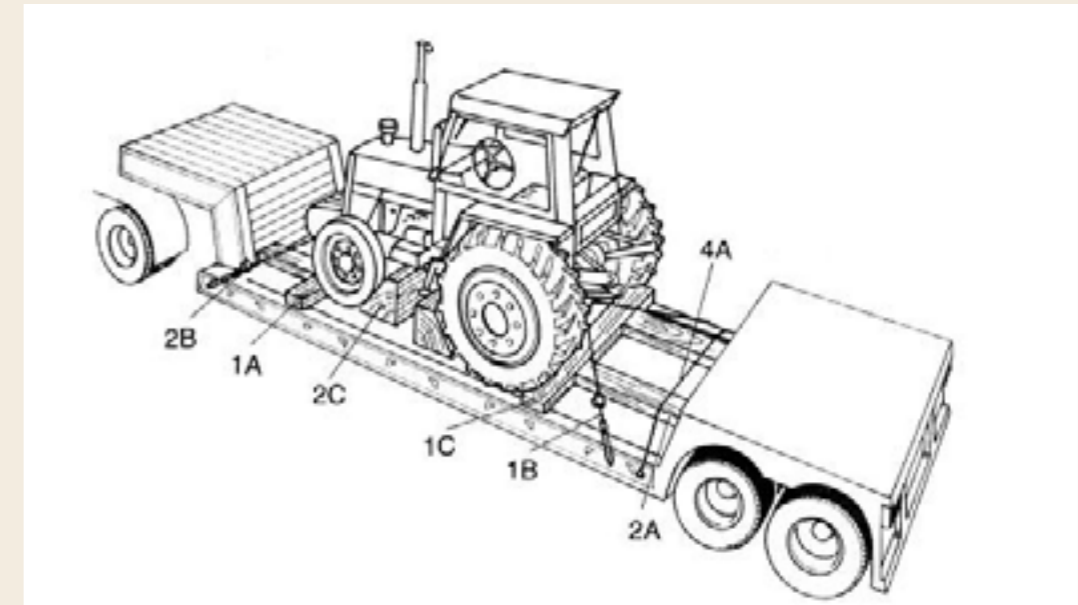

Vehicles carrying wheeled and light tracked vehicles

Wheeled and light tracked machines should be restrained so that the effect of bouncing caused by road shocks transmitted from the carrying vehicle and amplified by the machine's tyres or suspension units is minimised. Where possible the suspension unit of the machine should be locked and vertical movement limited by lashings or other means of restraint. Otherwise the machine's frame or chassis should be supported on blocks.

Vehicles carrying engineering plant

Heavy engineering plant is normally transported on purpose built vehicles which are specifically designed to provide easy loading and unloading facilities and are usually provided with adequate anchorage points for attaching the lashings. Lighter engineering plant may in some circumstances be carried on general-purpose vehicles. However, in these cases the method used to secure the load should provide equal security to that obtained by using purpose built vehicles.

Any plant or machinery that requires special 'out of the ordinary' starting or movement instructions, must have the necessary information readily available at the driver position.

It is not acceptable for verbal instructions to be given – these must be written. Please contact Customer Service Team in order that they can assist to avoid delays.

Vehicles carrying agricultural type tractors

Possible hazards	Precaution
1. Forward movement of machine	<p>A. Front wheels to be butted against bulkhead or against semi-trailer bulkhead.</p> <p>B. Lashing chains from rear towing hook to anchorage points on semi-trailer side members</p> <p>C. Rear wheels butted against chocks.</p>
2. Rearward movement of machine	<p>A. Rear wheels butted against bulkhead or against chocks against semi-trailer bulkhead.</p> <p>B. Lashing from front axle or towing hooks to anchorage point on semi-trailer side members.</p> <p>C. Front wheels butted against chocks.</p>
3. Sideways movement of machine	<p>A. Restraint provided by lashings used for forward and rearward restraint.</p>
4. Movement of ancillaries	<p>A. Lashing across bulking to anchorage points on semi-trailer side members.</p>

Vehicles carrying palletised loads

The safe carriage of pallets presents two main problems. Firstly there has to be considered the stability of the items stacked on the pallet and secondly the restraint of the pallet and its load on the semi-trailer platform. In the case of small containers and cased machinery, usually only the second factor needs be considered. When banding or other similar means are used to unitise a pallet and its load it is most important to appreciate that the banding etc. is intended only to keep the pallet and load together. Therefore it will be necessary to secure the entire unit to the vehicle. Securing the pallet alone is not sufficient.

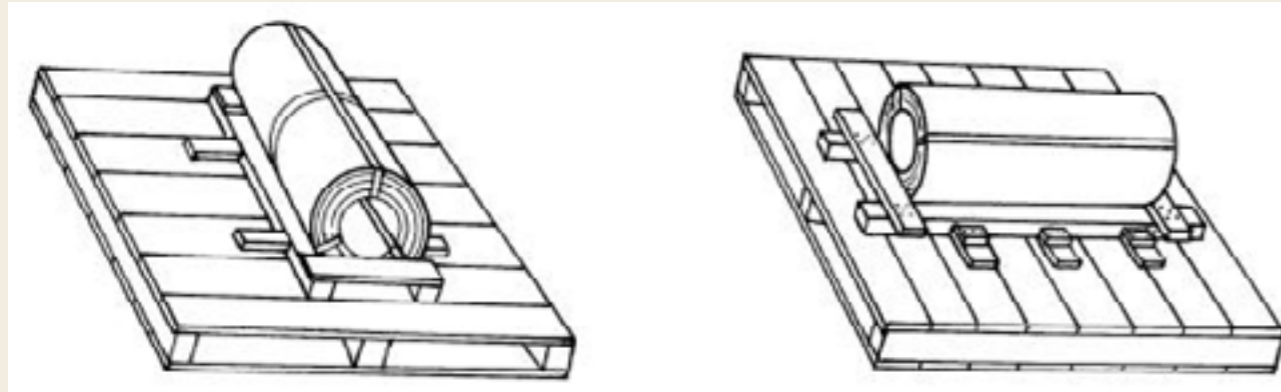

Example of securing of goods to a pallet

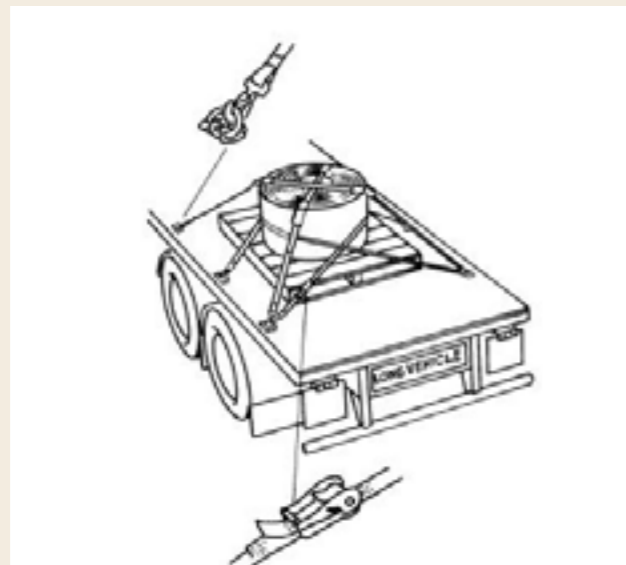

Example of securing of goods to a semi-trailer

Vehicles carrying rolls, drums, paper or cylindrical loads

Rolls or cylindrical items should ideally be placed with their axis across the vehicle so that the rolling tendency will be to the front or rear. In many circumstances additional dunnage, stopping blocks or wedges should be used, particularly on rounded sections where there is a tendency for roll to take place. This dunnage should be regarded as supplementary to the webbing restraints whose total strength should not be reduced because of its use.

When securing cylindrical items practical consideration should be given to how the load is to be unloaded in a safe and controlled manner.

On the left side of Figure No. 29 is a method of creating downward force on large tubular loads by using dunnage. The method used on the right creates the necessary downforce on smaller tubes by using folded sheet or other padding.

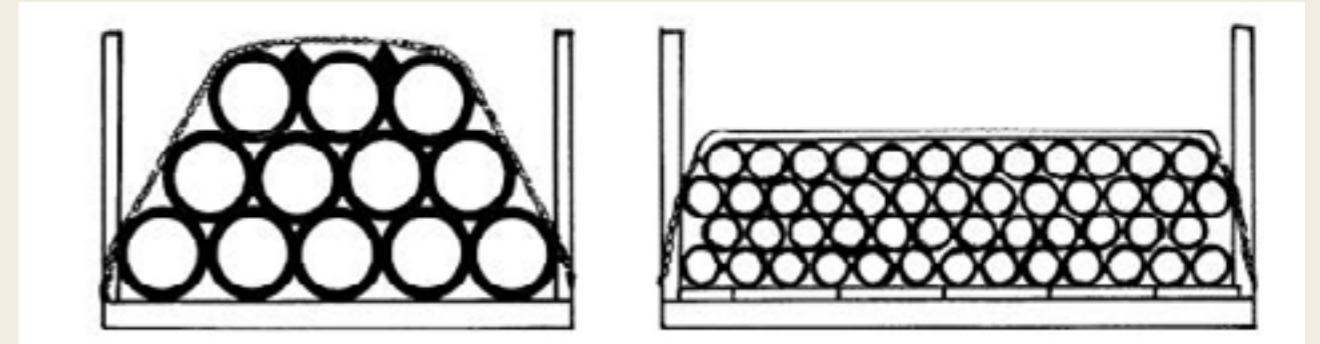

Insecure loads/partial loads

All loads must be secure on and/or within semi-trailers to avoid spilling out. The picture above depicts a load spillage on a ramp to our vessel. The picture on the right shows the load being restowed using the correct securing arrangements which would have prevented the spillage.



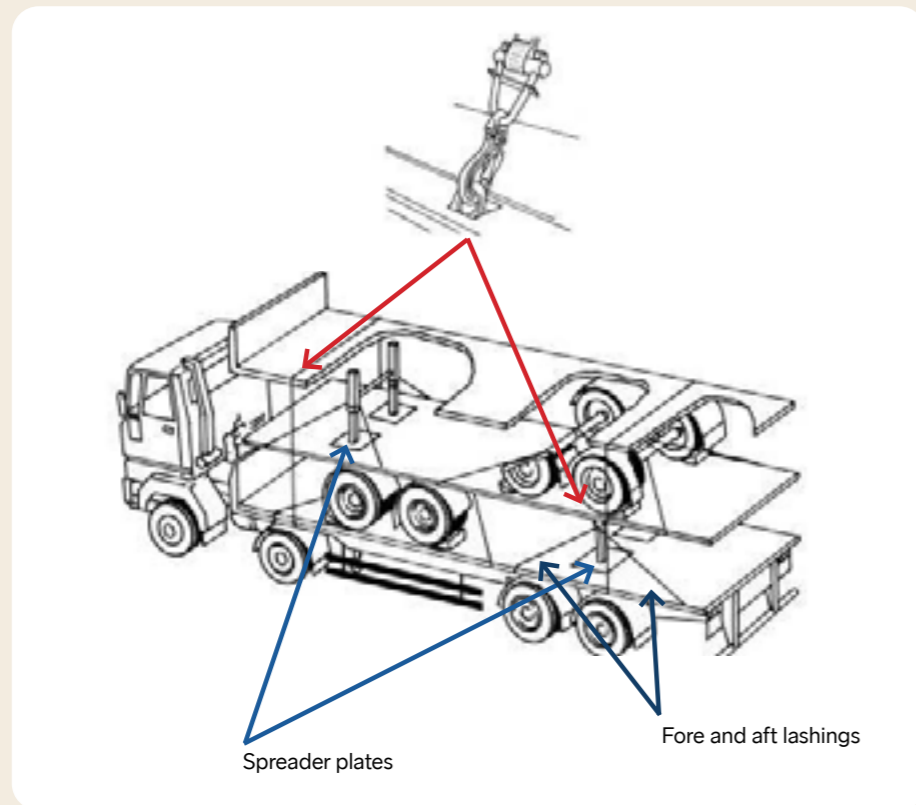

Vehicles carrying banked or stacked semi-trailers

Semi-trailers lashed together using appropriate straps and tensioning equipment (minimum 3 straps each)

The banking of semi-trailers must only take place with equipment that is suitable for that purpose, having appropriate lashing points in terms of number, position and strength. The top semi-trailer(s) should be parked with the parking brake 'on' and wheels chocked. The chocks should also be securely attached to the carrying vehicles deck.

The semi-trailer(s) being carried should be positioned so that their weight is fully supported by the carrying vehicle. If necessary spreader plates should be used to avoid high localised loading such as where the landing legs will be positioned.

Each semi-trailer being carried must be lashed to the carrying vehicle using appropriate lashing equipment. Tensioning devices must be fitted to each lashing, and the lashings used to restrain the fore and aft movement should be set at an angle of less than 60° from the horizontal to obtain the maximum effect (see figure no. 32 below). The lashing should be tested for adequate tension after the vehicle has moved a few miles and again on delivery at the port, and re-tensioned if necessary.

Lashings should only be fixed onto parts of the semi-trailers axles or chassis that are adequate for that purpose. If more than one semi-trailer is being carried in 'piggyback' fashion, then each semi-trailer should be lashed to the one on which it rests, and then all those carried should be lashed to the carrying vehicle.



Use of ropes for securing

If ropes are used for securing a load they should be made from polypropylene or polyester. Polyamide (nylon) ropes are not suitable as they tend to stretch under load. Sisal or manila ropes are also unsuitable as their strength is reduced by water saturation.

Ropes should be made of 3 strands and must have a minimum nominal diameter of at least 10 mm. The ends of the rope should be spliced or otherwise treated to prevent fraying. Rope should be selected in relation to the maximum force to be imposed in each lashing. The manufacturer must indicate the maximum authorised load for these ropes on an attached label or sleeve. Knots and sharp bends will reduce the strength of a rope and that wet ropes should always be allowed to dry naturally before use.



The above photograph (fig 33) shows an example of a load presented for shipment with insufficient lashings or sheeting. This load shifted on the quayside and not during shipment due to insufficient rope strength and improper securing arrangements.

Vehicles carrying concrete

The proper securing of concrete loads is of vital importance to ensure safe shipment and acceptance to ship. Proper corner pieces must be in place when straps are used to secure the cargo, paper or rags do not protect the straps from abrasion during shipment. When using chains to secure the corner pieces should be constructed of metal and when using straps the corner pieces shall be constructed of suitable plastic material as in fig no. 34. (Chains are the preferred option to secure concrete with suitable corner pieces to protect the concrete from damage during shipping)



It is important that concrete slabs are protected from causing friction damage by wood dunnage as in fig no. 34



There are many different types of concrete loads and but the principle applies in all cases as in fig no. 35.

Trailer Strength

When shipping cargo it is important that the semi-trailer used is of sufficient strength to carry the cargo presented and the cargo is spread as evenly as possible to ensure correct distribution of the load. See fig no. 36 & 37 as incorrect loading of semi-trailers presented



Incorrect weight balance, fig no. 36



Check the wooden floor maximum weight capacity, fig. no 37

4. Bookings

Bookings can be made by contacting your local Freight Reservations & Customer Service teams. You can find all information through the website www.stenalinefreight.com/contact

If you are a registered customer you can use our online booking programmes available, if you would like more information on these systems please ask your local Stena Line team or visit www.stenalinefreight.com

4.1 Information required

Your Reservation team will guide you through the booking requirements which will include:

- Route, date and time of sailing
- Account details for invoicing purposes
- Dimensions of the load
- Particulars of equipment/cargo type for example: hazardous, running reefer, tank. Abnormal load or mobile
- Vehicle registration or semi-trailer number, cargo details if known
- Number of drivers if applicable
- Your customer reference number if applicable

4.3 Abnormal loads (over-width, bulging etc.)

Full details of maximum weight, height, width and overall length

4.4 Confirmation

Once the booking has been made the Reservation team will confirm the booking back to you.

4.6 Cancellations

Failure to make regular use of agreed booking allocations without the appropriate notification may result in a review of these allocations

5. Arrival at the terminal

5.1 High visibility clothing

High visibility clothing may be required to be worn in our ports, at our terminals or in certain areas. It is the customers' responsibility to ensure that drivers or agents acting on their behalf are provided with these and that they are worn when required.

Any driver or contractor who does not provide proof that they are in possession of a high visibility clothing at the entrance to the terminals may be refused entry.

Any driver or contractor observed at our terminals not wearing high visibility clothing in a designated high visibility clothing area may be asked to leave.



5.2 ISPS regulations and ID requirements

Failure to be in possession of valid identification may result in entry to the port facility being denied.

5.3 Speed limits

Displayed speed limits must be adhered to at all Stena Line terminals. It should be noted that in some terminals the police enforce local country driving regulations.

5.4 Cut-off times for shipment

Please contact your local Customer Service Team for details or visit online www.stenalinefreight.com

5.5 Use of mobile phones

The use of mobile phones whilst driving in the terminal area and driving on our vessels is prohibited.



5.6 Weight

All drivers should declare the combined weight of the semi-trailer and contents when prompted at check-in.

5.7 Paperwork

Any paperwork relating to the equipment, load or destination should be placed inside the equipment.

5.8 Driving around the Terminal and on board

Drivers must take extreme care and be aware of other moving traffic which may be considerable, particularly when vessels are unloading traffic. Drivers must follow the road signage in place and not cut across traffic lanes and follow all directions and instructions given by the Port staff and ship crew.

5.9 Parking in the terminal

Drivers dropping off semi-trailers in the Terminal must lower the landing legs (see figure no. 34) and ensure the parking brake on the semi-trailer is activated prior to disconnecting the airlines if not automatic. (In some of our terminals it is not necessary to lower the landing legs as there

are raised platforms, the driver will be advised of this if it is applicable by the check-in staff). Whenever a driver dismounts from his cab unit he must ensure the parking brake is fully engaged.



5.10 Drugs and Alcohol

Drivers suspected, or found to be under the influence of drugs or alcohol whilst driving in our terminals will be refused shipment and banned from further entry to the port.

5.11 Abusive behaviour

Abusive behaviour, either physical and/or verbal, directed at our staff or our other customers will not be tolerated under any circumstance. Appropriate action, including removal from the port or vessel and a report to the authorities may be taken.





6. Check in

6.1 Booking reference numbers

This will be communicated to you during the booking stage. Please give your driver/agent this number prior to arrival at the port.

6.2 Storage

As space is at a premium, storage of equipment may be prohibited at some of our terminals.

6.3 Load description

The driver will also be asked the contents of the load if it has not already been declared at the time of booking. A driver may also be asked to present the manifest if the contents are declared as 'Groupage'. In some terminals it is mandatory to present cargo papers detailing the content of the load, please contact CST.

6.4 Hazardous goods paperwork and DGN's

The shipper is responsible to declare all dangerous goods classified under the IMDG code for shipment at the time of booking. (See Section 9)

6.5 Hazardous labelling

All hazardous units presented for shipment must be correctly labelled/placarded correctly.

6.6 Refrigerated Loads

Customers must advise the CST of their intention to ship a refrigerated unit at the initial booking stage quoting temperature requirements.

6.7 Overfilling of fuel tanks

Customers are requested to ensure that when fuelling their vehicles prior to shipment, they allow adequate ullage (space) in their tanks to ensure that spillages do not occur either in the process of boarding vessels by means of shore and ship's ramps or as a result of being parked upon such ramps.

7. Security

7.1 Freight screening

Under the International Ship and Port Facility (Security) Regulations, all ferry operators have a legal obligation to facilitate check and search procedures for varying percentages of freight vehicles presented for shipment, dependent upon the security level at which the port is operating.

As a consequence of this legislation your driver may be subject to search and/or questioning by security staff upon arrival at the port. Furthermore, the load may be subject to screening by the authorities. This searching/screening is entirely random and across all unit types and customers, and will take at least one of the following forms

- ➔ a search of the cab interior including contents
- ➔ a body search of the driver and any passengers (subject to national legislation)
- ➔ a check of the exterior and interior of the vehicle

Any person failing to make themselves or their vehicle available for search or questioning will be refused entry into the port facility.

8. Delivery of units to the terminal for shipment

8.1 Drivers responsibilities

Whilst visiting drivers are on the quay they have a duty of care to ensure that they adhere to all the regulations in force on the quayside. This includes

- delivering the unit to the area of the terminal as directed by Stena Line staff
- giving way to tug masters driving on the quay
- adhering to the traffic plan and speed limits
- being aware of pedestrians on the quay
- being aware of other drivers in lanes putting on lights and lenses on semi-trailers
- not damaging other semi-trailers, fences and property when parking semi-trailers
- drivers must wear high visibility clothing in designated high vis areas

8.2 Driver accompanied vehicles

During check-in process the driver of the vehicle will be asked

- length
- weight
- width
- height
- full name
- date of birth
- nationality

* Note the use of APU's (Auxiliary Power Units) on board

Additionally, if requested, they must provide

Due to fire risk we would like to take this opportunity to ask you to remind your drivers of the importance of ensuring that any fuel-fired heaters, Auxiliary Power Units* (APUs), fuel cells or battery packs are disengaged once their vehicle has been safely stowed on board the vessel.

(*This technology provides vehicles with AC / DC electrical power which may be used to power air conditioning, heating or ancillary electrical appliances)

It is strictly prohibited and against maritime law for drivers to sleep in their cabs during transit. Once on board the vessel the driver must exit their cab and proceed to the Freight Driver facilities.

On discharge at the port of arrival driver accompanied units must exit the port immediately with the manifested trailer.

8.3 Collection from the terminal

We have release procedures in place at all our terminals to prevent theft. In order to collect a piece of equipment from our terminals the collecting driver must provide the following

- photographic ID
- booking reference
- semi-trailer number/serial number/registration number
- registration number of the cab unit if collecting an unaccompanied semi-trailer

Some companies have further procedures specifically agreed and these are enforced alongside our own – they do not replace ours.

Failure to provide any of the above may lead to delays in collection and consequently delays in delivery to your customers.

Once the bona fide of the collecting driver has been established they will be issued with a release note. The copy of which must be presented to the security guard at the exit point of the terminal.

In some of our terminals all equipment must be collected no more than 24 hours post arrival.



9. Shipment of specialised goods

9.1 Hazardous goods

With the exception of the area covered by the 'Baltic Agreement' and any rail traffic Stena Line will only accept for shipment hazardous goods that comply with the requirements of the latest edition of the International Maritime Dangerous Goods (IMDG) code. For hazardous goods shipment within the Baltic area or by Rail transport please contact our Customer Service Team.

The International Maritime Dangerous Goods (IMDG) code was developed as a uniform international code for the transport of dangerous goods by sea covering such matters as packing, container traffic and stowage, with particular reference to the segregation of incompatible substances. The code lays down basic principles, detailed recommendations for individual substances, materials and articles. There are a number of recommendations for good operational practice including advice on terminology, packing, labelling, segregation and handling, and emergency response action.

The following information is always required on IMDG Code dangerous goods shipping documentation

1. Proper Shipping Name
2. Class
3. United Nations (UN) number
4. Number and kind of packages
5. The packing certificate (or the DG Certificate signed by the packer)
6. A Marine Pollutant declaration
7. Total quantity of dangerous goods
8. Declaration signed on behalf of the shipper

When a driver arrives at the port he will be asked for all the original hazardous documentation and this will be checked to ensure it has been completed correctly; however, it is the responsibility of the shipper/driver to ensure that appropriate placards are in place and removed on completion of the crossing.

Please be aware that placards on semi-trailers for shipment by sea are different to those used by road.

Under the IMDG Code, a vehicle must, at least when presented for carriage by sea, be placarded on both sides and the back of the vehicle, with placards representing each of the various danger labels which may be applied to the packages within the vehicle. This applies whether the vehicle has only one fully regulated package loaded, or is loaded to capacity with fully regulated dangerous goods packages.

When carrying only Limited Quantities (LQ) packages, whatever the quantity of such packages loaded, the vehicle must be marked when presented for carriage by sea, with an enlarged LQ mark on both sides and at the rear.

Note: If the vehicle is also carrying fully regulated dangerous goods then it is not necessary to display the LQ mark, as the appropriate class hazard placard(s) must be displayed.

Additional note regarding the shipment of hay/straw

All shipments of straw must be accompanied by a DGN which should clearly state the moisture content as a percentage. If the moisture content is not shown on the DGN then the load will be rejected for shipping.

Stena Line will only accept loads with a declared moisture content of 17% and below. All shipments of hay/straw must be fully covered and any loads not so will be rejected (this being considered as incorrect packaging).

The Customer Service Team will further advise as to whether the dangerous goods to be presented for shipment are allowed.

9.1 Animals

We can ship livestock on some of our vessels, however animal welfare is an issue that concerns us. Therefore, in keeping with our animal welfare policy, we reserve the right to refuse any shipment of livestock if we deem the shipment to be in violation of animal rights.

Please refer to [our website](#) for further details.

It is prohibited for drivers to open ventilation louvres on board the vessel. Ventilation louvres etc. must be open prior to driving on the vehicle deck. In accordance with national requirements welfare visits during passage are generally obligatory and Stena Line will facilitate those visits. For shipment of other types of animals, such as circus animals please contact our Customer Service Team.

9.2 Horses

We do not accept shipment of horses on all our routes. Please contact the Customer Service Team for further information. If you do wish to ship horses you will be required to produce the necessary national regulatory paperwork.

9.3 Refrigerated cargo (reefers)

Reefer units are the single most frequent source of fires on ro-ro decks, powered by either electrical cable or a dedicated diesel unit. Due to this increased fire risk, reefers are identified as high risk cargo. A well maintained reefer unit is paramount for safe transport and therefore Stena Line has the right to refuse any reefer units for shipment that the Master of the vessel does not assess to be in a safe condition and furthermore will not accept any liability for this refusal.

Stena Line therefore urges the haulier/driver to ensure that any reefer unit due for shipment on a Stena Line vessel is well maintained with all functions and electrical connections in good working order.

9.4 Scrap metal

All shipments of scrap metal and/or containing scrap metal, including but not limited to aluminum swarf/turnings, metal turning/shavings/borings, are subject to a pre-declaration by the Merchant that needs to be made to Stena Line prior to the presentation of the Goods for carriage. The Merchant shall be liable for any damage, loss and expense, howsoever caused, if said requirement is not complied with.

10. Damages

Please contact your local claims department which can be found on our website www.stenalinefreight.com/FAQ/claims-handling

11. Insurance

Insurance covering transportation of loads on trailers and articles of transport is not the responsibility of Stena Line. Insurance should be arranged by the transporting customer/forwarder.

Stena Line will not accept liability for damage to equipment, or cargo, which the owner has left on the terminal for more than 24 hours after arrival without prior agreement.



Contact

Stena Line Scandinavia AB | SE-405 19 Gothenburg | +46 (0)31 85 80 00

www.stenalinefreight.com

